

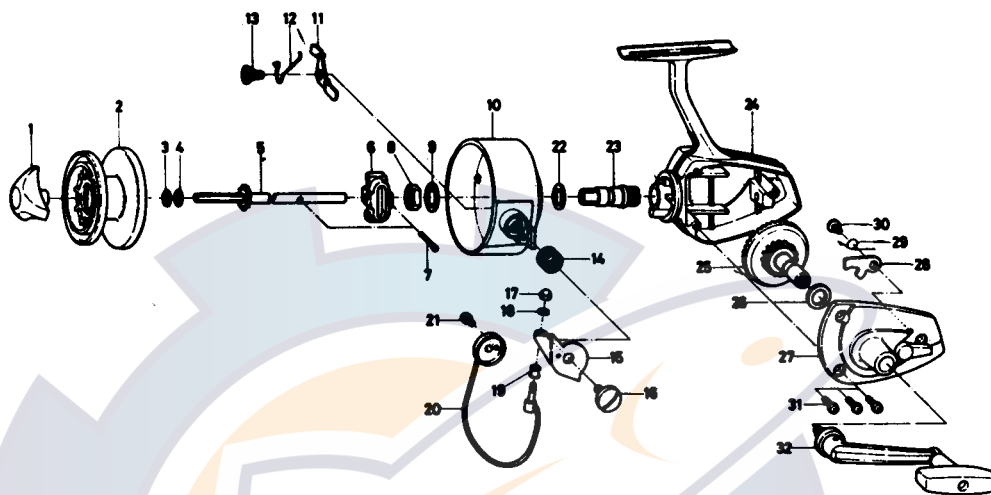

SPINNING REEL 403



LINE CAPACITY: 250 YDS., 8 LB. TEST (250m Dia. 0.27mm)

Key No.	Parts No.	Parts Name	Key No.	Parts No.	Parts Name
1	6-740-3001	Drag knob	17	6-341-9901	Bail nut
2	6-732-2001	Spool	18	6-160-0121	Bail washer
3	6-374-6401	Spool washer A	19	6-250-3801	Line roller
4	6-374-6400	Spool washer B	20	6-725-6801	Bail
5	6-711-1801	Main shaft	21	6-352-0401	Bail holder screw
6	6-481-1601	Oscillating slider	22	6-371-6420	Pinion washer
7	6-490-4301	Oscillating slider pin	23	6-402-6501	Pinion
8	6-340-6602	Rotor nut	24	6-700-8901	Body
9	6-160-1611	Rotor washer	25	6-413-5301	Drive gear
10	6-201-9001	Rotor	26	6-371-2820	Drive gear washer
11	6-570-9501	Bail kick lever	27	6-706-4001	Body cover
12	6-140-6231	Bail kick lever spring	28	6-111-5501	Anti-reverse claw
13	6-361-1512	Bail kick lever screw	29	6-141-1581	Anti-reverse claw spring
14	6-140-9231	Bail spring	30	6-350-1931	Anti-reverse claw screw
15	6-230-7011	Arm lever	31	6-351-6401	Body cover screw
16	6-363-1311	Arm lever screw	32	6-746-5301	Handle

Darwa

Page
173

Date
1-77

Rev. No.
00